

CEDAR OAKS RETAIL

FOR LEASE IN WEST LINN, OREGON



LOCATION

18750 Willamette Drive
West Linn, Oregon 97068

AVAILABLE SPACES

- 1,216 SF (former martial arts studio)
- 951 SF (former med spa, 3 private rooms)

RENTAL RATE

Please call for details

HIGHLIGHTS

- Located in an upscale suburban community on Hwy 43.
- Great visibility and easy access.
- Tenants in the immediate area include AT&T, Bugatti's and The Barbers.
- Affluent residential population.

TRAFFIC COUNT

Willamette Dr – 17,460 ADT ('22)



COMMERCIAL
REALTY ADVISORS
NORTHWEST LLC

Rob Kimmelman
503.449.2591 | rob@cra-nw.com

503.274.0211
www.cra-nw.com

CEDAR OAKS RETAIL
18750 WILLAMETTE DRIVE
WEST LINN, OR

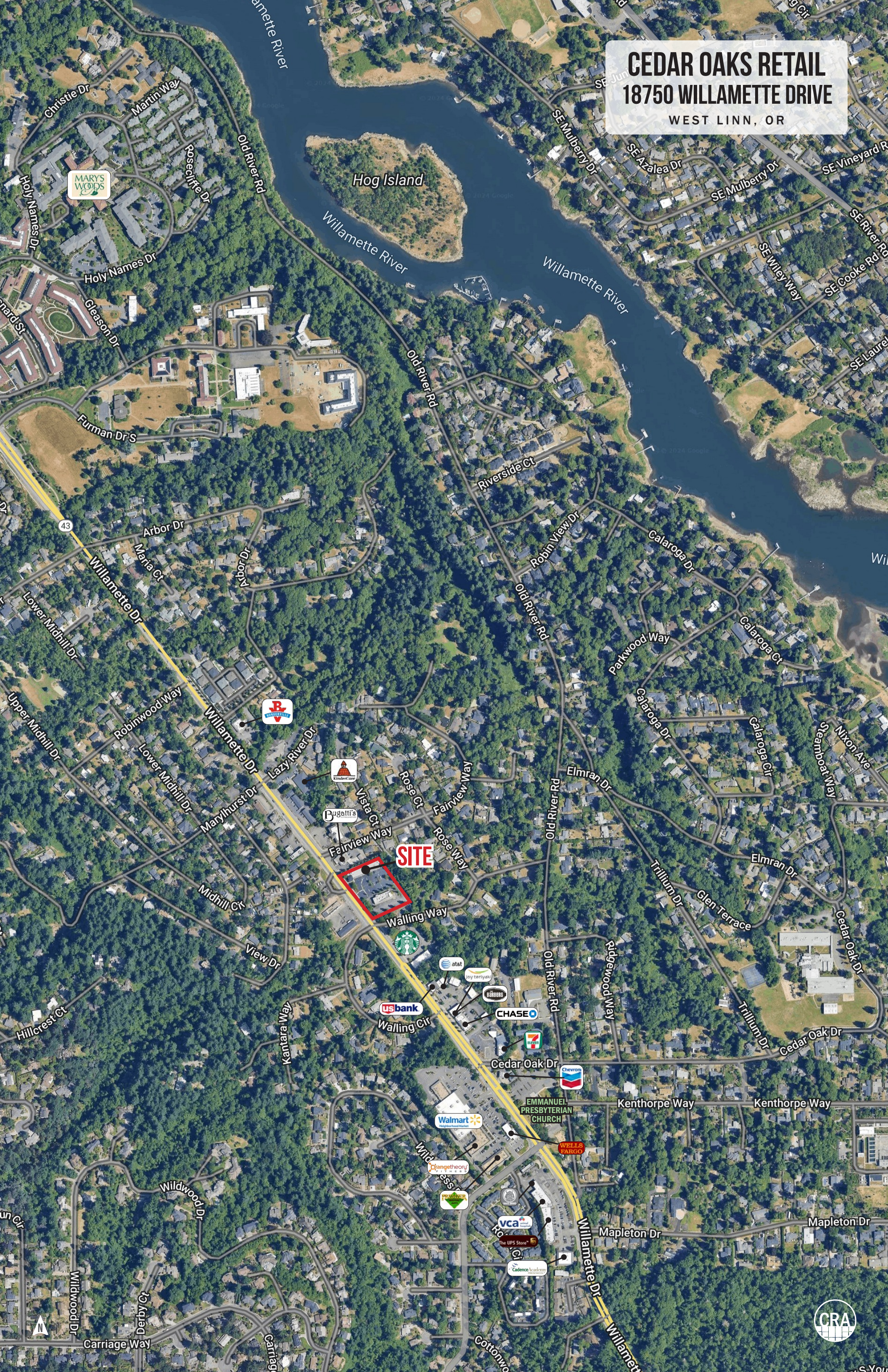

CEDAR OAKS RETAIL

18750 WILLAMETTE DRIVE

WEST LINN, OR

SITE PLAN

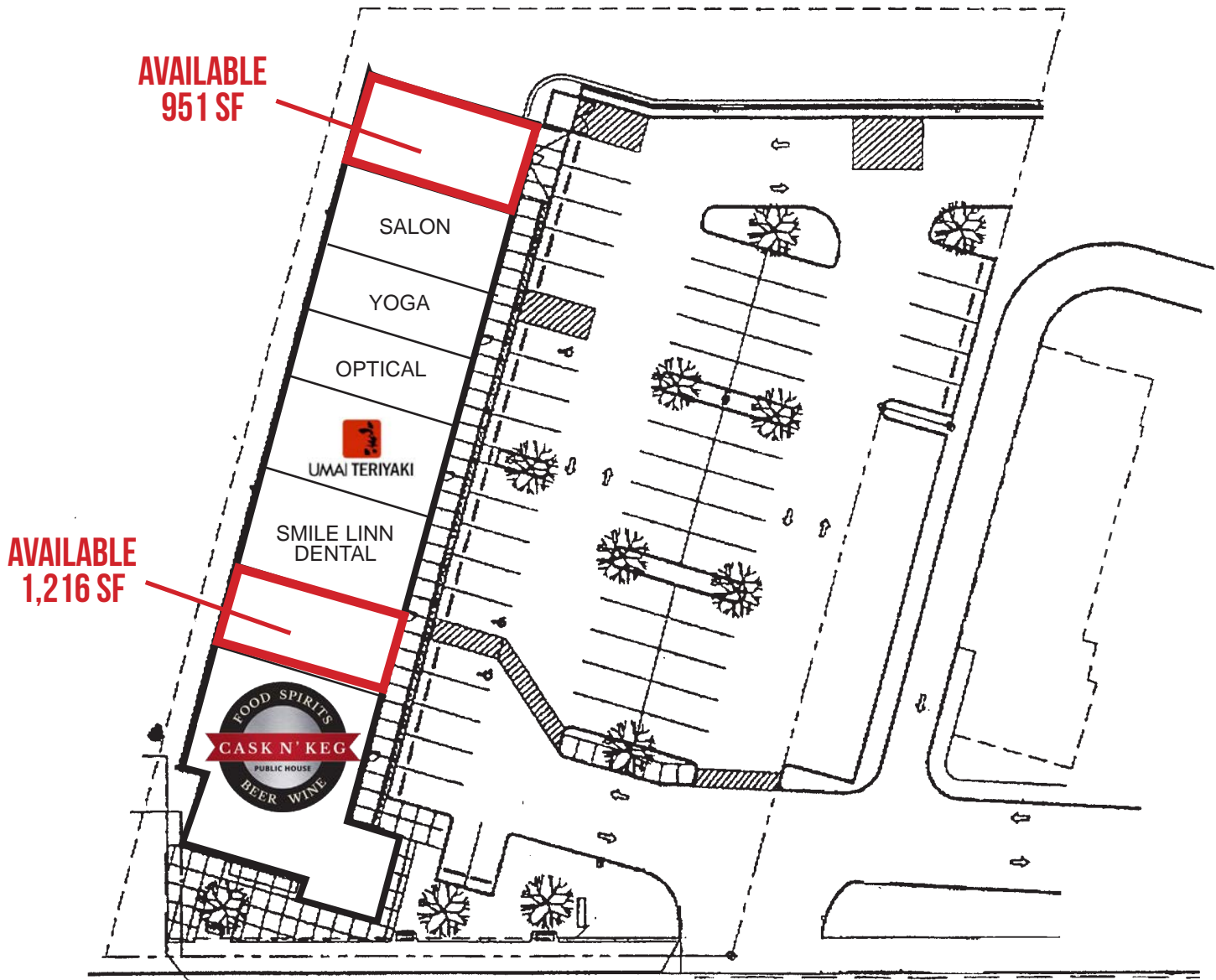

HWY 43 / WILLAMETTE DR



The information contained herein has been obtained from sources Commercial Realty Advisors NW LLC deems reliable. We have no reason to doubt its accuracy, but Commercial Realty Advisors NW LLC does not guarantee the information. The prospective buyer or tenant should carefully verify all information obtained herein.

CEDAR OAKS RETAIL

18750 WILLAMETTE DRIVE

FLOOR PLAN | 1,216 SF

WEST LINN, OR

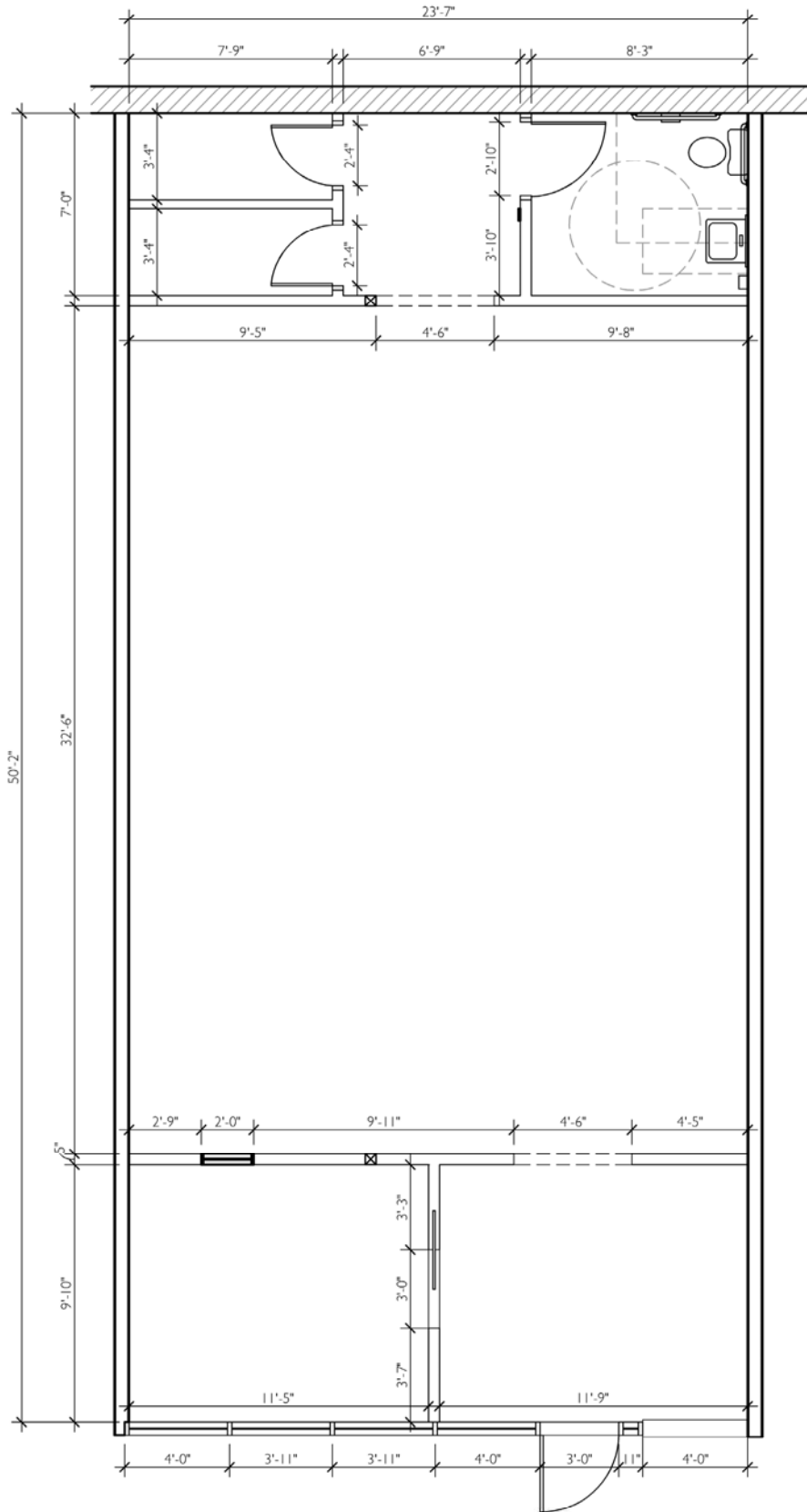

The information contained herein has been obtained from sources Commercial Realty Advisors NW LLC deems reliable. We have no reason to doubt its accuracy, but Commercial Realty Advisors NW LLC does not guarantee the information. The prospective buyer or tenant should carefully verify all information obtained herein.

CEDAR OAKS RETAIL

18750 WILLAMETTE DRIVE

FLOOR PLAN | 951 SF

WEST LINN, OR

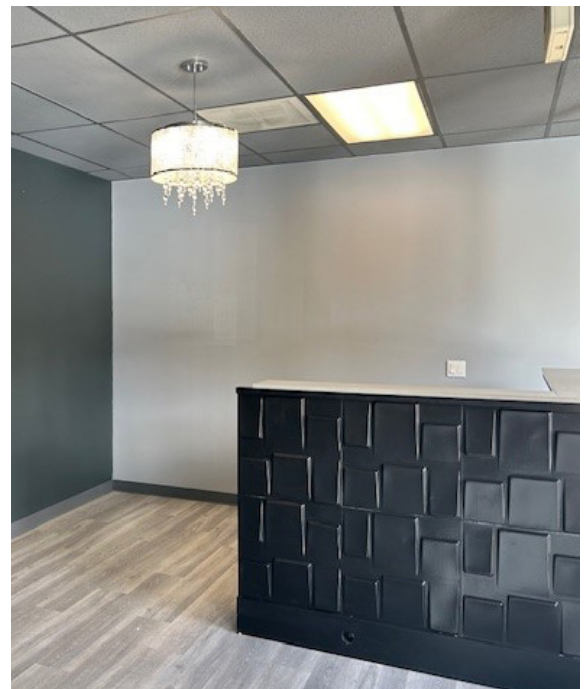
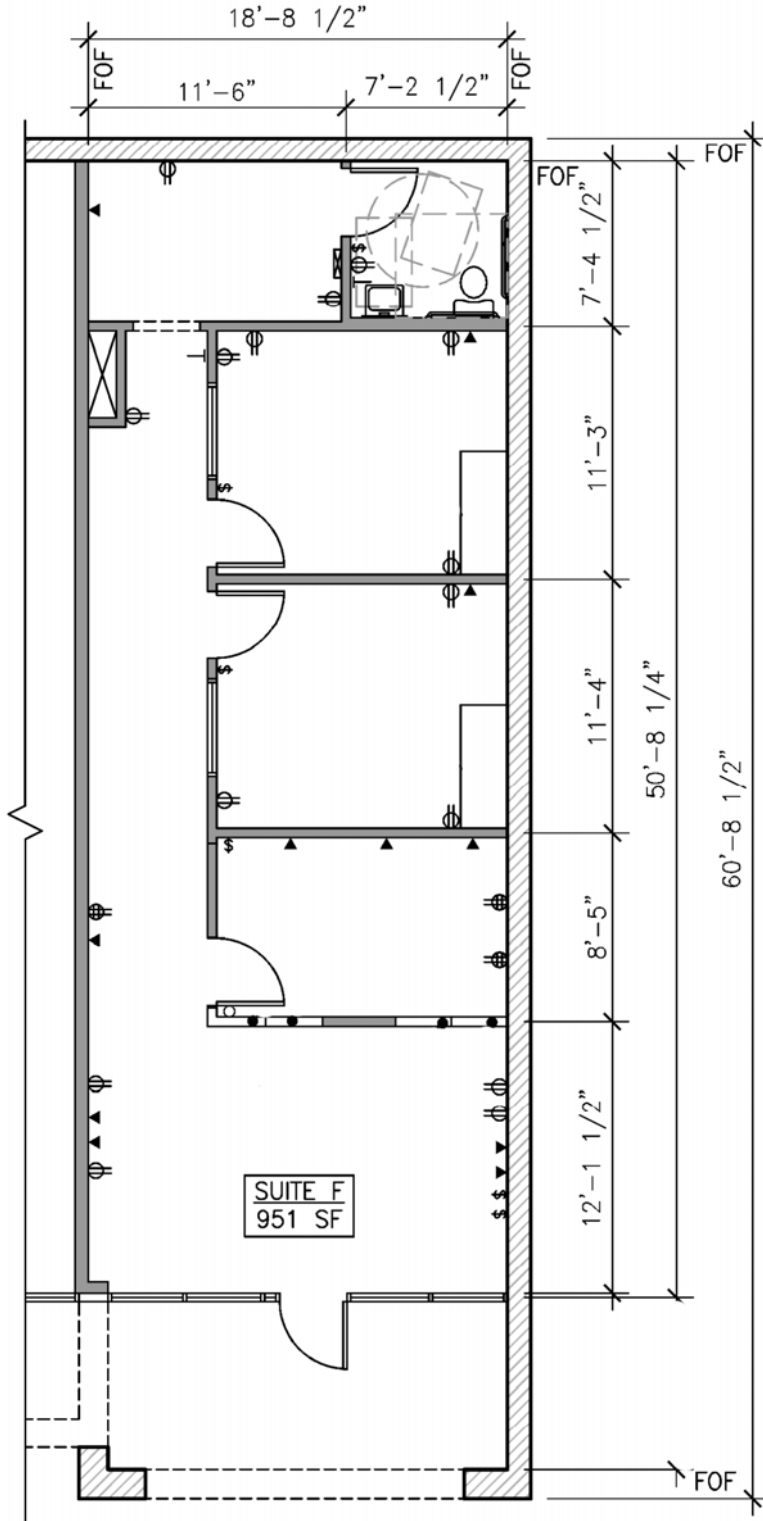

The information contained herein has been obtained from sources Commercial Realty Advisors NW LLC deems reliable. We have no reason to doubt its accuracy, but Commercial Realty Advisors NW LLC does not guarantee the information. The prospective buyer or tenant should carefully verify all information obtained herein.

CEDAR OAKS RETAIL 18750 WILLAMETTE DRIVE

WEST LINN, OR

DEMOGRAPHIC SUMMARY

Source: Regis - SitesUSA (2024)	1 MILE	3 MILE	5 MILE
Estimated Population 2024	9,389	82,525	205,393
Estimated Households	3,948	34,028	84,325
Average HH Income	\$189,419	\$159,680	\$152,942
Median Home Value	\$724,669	\$681,973	\$671,066
Daytime Demographics 16+	6,067	55,085	160,461
Some College or Higher	85.4%	78.1%	76.7%

\$189,419

Average Household Income
1 MILE RADIUS

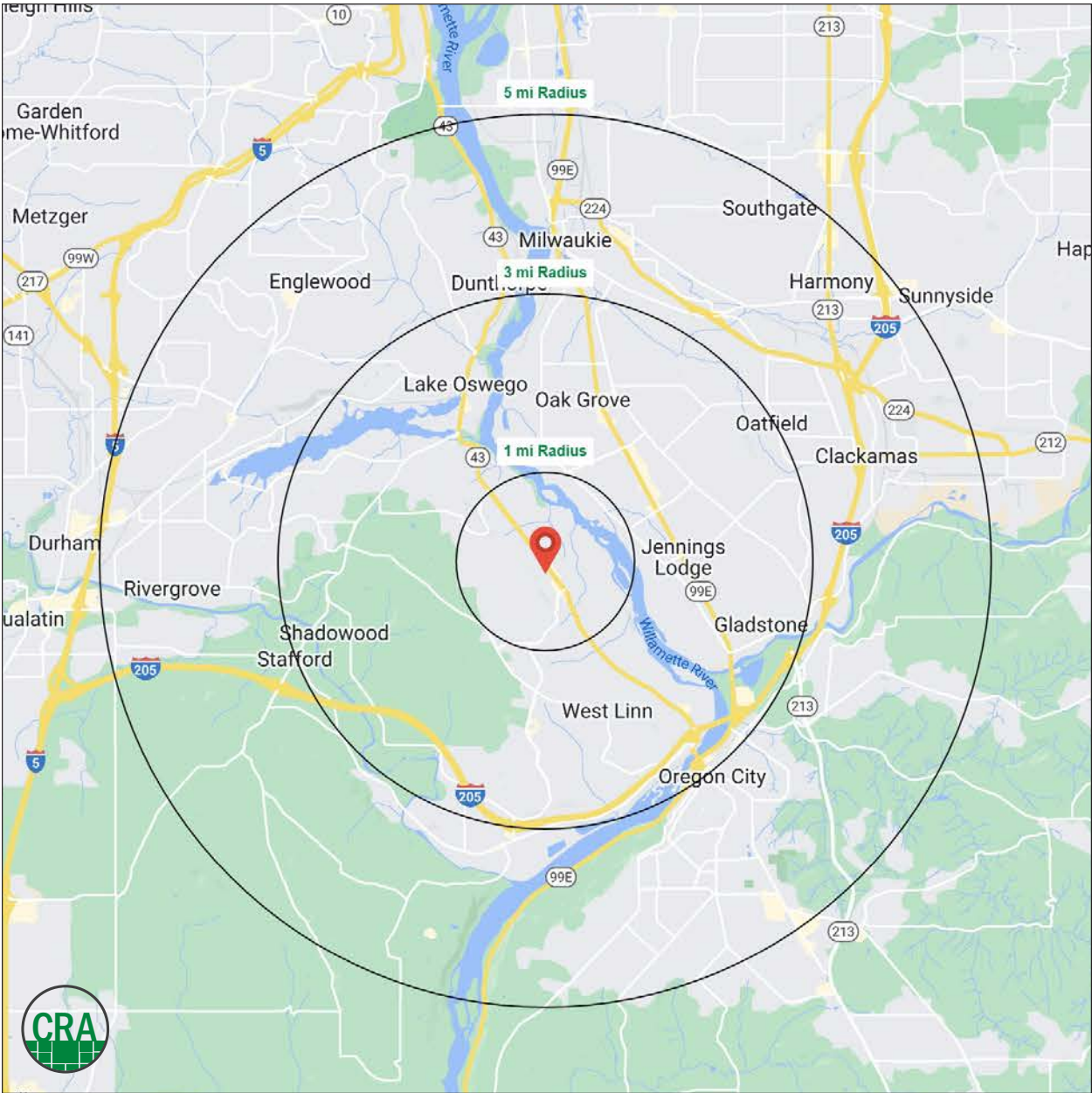

Summary Profile

2010-2020 Census, 2024 Estimates with 2029 Projections
 Calculated using Weighted Block Centroid from Block Groups



Lat/Lon: 45.3903/-122.6441

18750 Willamette Dr West Linn, OR 97068	1 mi radius	3 mi radius	5 mi radius
Population			
2024 Estimated Population	9,389	82,525	205,393
2029 Projected Population	9,233	81,483	204,570
2020 Census Population	9,865	83,728	207,167
2010 Census Population	8,509	78,041	192,146
Projected Annual Growth 2024 to 2029	-0.3%	-0.3%	-
Historical Annual Growth 2010 to 2024	0.7%	0.4%	0.5%
2024 Median Age	51.3	44.7	42.5
Households			
2024 Estimated Households	3,948	34,028	84,325
2029 Projected Households	3,918	33,882	84,815
2020 Census Households	3,984	33,441	82,792
2010 Census Households	3,390	31,516	77,804
Projected Annual Growth 2024 to 2029	-0.2%	-	0.1%
Historical Annual Growth 2010 to 2024	1.2%	0.6%	0.6%
Race and Ethnicity			
2024 Estimated White	85.5%	84.0%	82.5%
2024 Estimated Black or African American	0.8%	1.4%	1.7%
2024 Estimated Asian or Pacific Islander	5.6%	4.8%	5.4%
2024 Estimated American Indian or Native Alaskan	0.3%	0.5%	0.5%
2024 Estimated Other Races	7.8%	9.3%	9.9%
2024 Estimated Hispanic	6.1%	8.2%	8.8%
Income			
2024 Estimated Average Household Income	\$189,419	\$159,680	\$152,942
2024 Estimated Median Household Income	\$133,079	\$115,076	\$109,983
2024 Estimated Per Capita Income	\$79,826	\$65,977	\$62,972
Education (Age 25+)			
2024 Estimated Elementary (Grade Level 0 to 8)	1.5%	2.1%	1.9%
2024 Estimated Some High School (Grade Level 9 to 11)	1.0%	2.9%	2.8%
2024 Estimated High School Graduate	12.2%	17.0%	18.6%
2024 Estimated Some College	18.4%	20.2%	20.6%
2024 Estimated Associates Degree Only	5.9%	7.6%	7.6%
2024 Estimated Bachelors Degree Only	36.2%	30.5%	29.7%
2024 Estimated Graduate Degree	24.9%	19.7%	18.7%
Business			
2024 Estimated Total Businesses	475	4,728	13,320
2024 Estimated Total Employees	2,383	25,432	90,262
2024 Estimated Employee Population per Business	5.0	5.4	6.8
2024 Estimated Residential Population per Business	19.8	17.5	15.4

For more information, please contact:

ROB KIMMELMAN 503.449.2591 | rob@cra-nw.com



KNOWLEDGE

RELATIONSHIPS

EXPERIENCE



**COMMERCIAL
REALTY ADVISORS
NORTHWEST LLC**

Licensed brokers in Oregon & Washington

 15350 SW Sequoia Parkway, Suite 198 • Portland, Oregon 97224

 www.cra-nw.com

 **503.274.0211**

The information herein has been obtained from sources we deem reliable. We do not, however, guarantee its accuracy. All information should be verified prior to purchase/leasing. View the Real Estate Agency Pamphlet by visiting our website, www.cra-nw.com/home/agency-disclosure.html. CRA PRINTS WITH 30% POST-CONSUMER, RECYCLED-CONTENT MATERIAL.